

Hence, we have extended our prototype simulator [1] to simulate two distinct environments onto one simulation platform. This extension can simulate normal air interfaced networks as well as specific metal pipeline monitoring applications. It can also simulate wireless network management schemes such as routing and sleep scheduling algorithms.

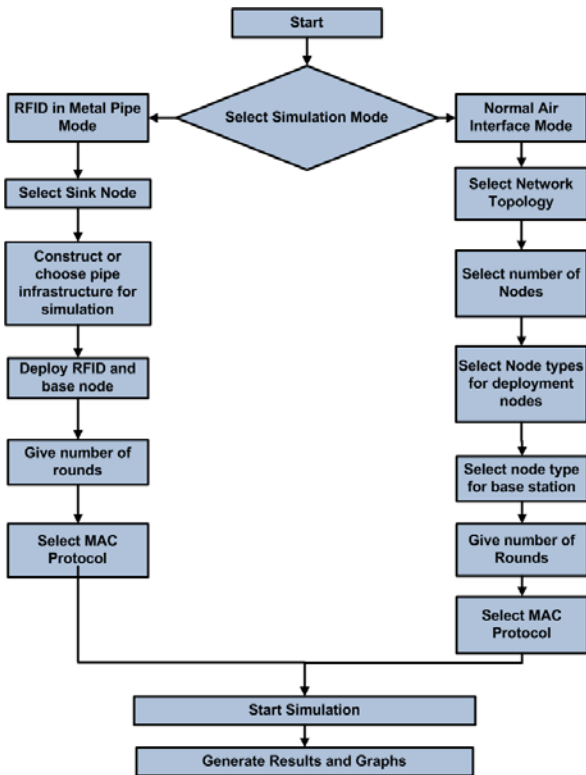

Figure 1: Simulator's Flow Diagram.

Our extension provides many kinds of useful simulation results, nodes residual energy, energy consumption and the number of living nodes at the end of the simulation. Dijkstra algorithm [27] was chosen to find the shortest path between the nodes and the sink with two cost functions based on energy and distance between the nodes. This simulator can offer two default MAC schemes SMAC [19] and TMAC [20] to choose from apart from customizing a new protocol. We have also been deploying normal air interfaced motes such as imote2 [15], TelosB [16], MicaZ [17] and Gumstix computers [18] in our work related to vehicular and urban sensing and in-pipe water monitoring [1, 24-26, 28-30]. We were faced with the challenge of simulating these two different environments and applications into a single simulator. Based on the performance, we can show that EnergySim is dynamic, flexible and it can support various kinds of MAC protocols and gives us more real life results.

The rest of this paper is organized as follows. Section 2 details design and implementation of EnergySim along with detailed EnergySim usage instructions, section 3 explains the working of the two simulation engines, section 4 gives some details of possible future work and finally, section 5 concludes the paper.

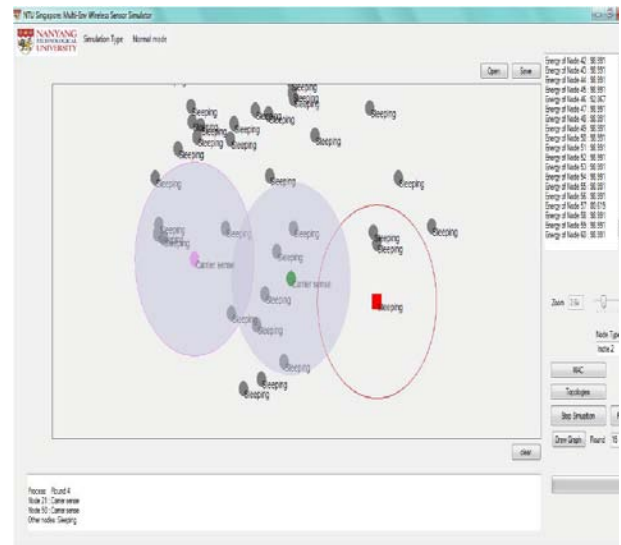

Figure 2: Random nodes Deployed on the simulation screen.

II. MULTI- ENVIRONMENT SIMULATOR

A. Introduction

Our proposed simulator is a versatile event driven simulating platform capable of simulating multiple environments. It is based on C# visual programming language which offers an ease of Visual Basic and object orientation of Java. C# was chosen because of portability of applications provided by the .Net runtime. This enables our software to run on any .NET compliant operating system making it platform independent. Some important benefits that C# provides include dynamic implementation of sensor nodes, graphical support using GDI plus API, interoperability with different

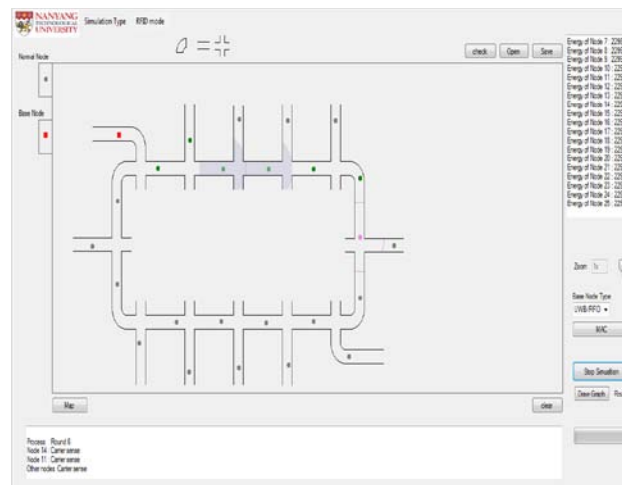

Figure 3: RFID Mode.

packages like Microsoft Excel and MATLAB. Our simulator generates Excel worksheets and plots of the energy states after the simulation. Similarly, any other software package can also be linked. Another benefit provided by C# includes rapid prototyping, scalability of code (new protocols can be easily

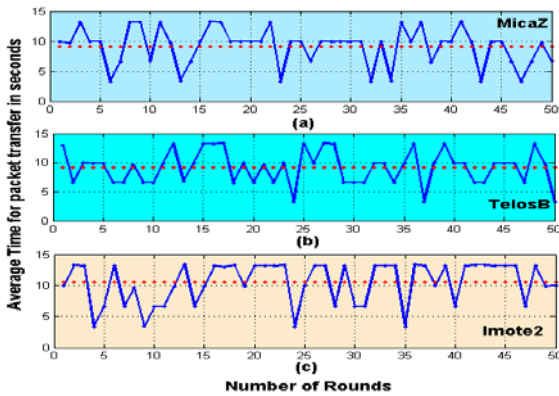

Figure 5: Average time consumed in seconds for packet transfer for 100 nodes in 50 rounds in Random topology. Red lines show the mean time values for 50 rounds. (a) MicaZ (b) TelosB and (c) Imote2.

accommodated) etc. Furthermore, the component based architecture enables appending new features easy.

B. Design and Implementation

Fig. 1 shows the flow of the EnergySim simulator. The simulation begins after user chooses the environment (RFID in-pipe or normal air interface) and then submits the input parameters according to the MAC protocol. The parameters include number of nodes, number of rounds, initial node energies, threshold energy, energy consumption in sleep and idle modes, node's communication range, topology etc. After taking the inputs and before the "simulate" button is pressed the simulator deploys the nodes on the simulation space as per the selected topology in case if air interface option is chosen otherwise, it will allow the user to either make a pipe network using tools provided or download a piping map structure and deploy the RFID sensors motes inside the pipe. Afterwards, a random node is selected and the simulator determines the shortest path using Dijkstra algorithm from this node to the sink node (an air interfaced node in case of RFID in-pipe mode). Once the path is established the nodes start communicating by sending control signals and show all the intermediate states of the communication as per the chosen MAC protocol.

The simulator tallies the number of rounds entered by the user to the actual simulated rounds and if found unequal it resumes the simulation till the number of rounds elapsed are equal to the given number of rounds. After completion of the rounds the simulator generates Excel worksheet and graph plot when the "Draw Graph" button is pressed, as shown in Fig. 2 for Normal mode and Fig. 3 for RFID mode.

C. Properties

Here we list some of the unique properties of EnergySim. The sensing radius and the range within the metallic pipes of the nodes can be altered by the user. This helps to evaluate different wireless nodes with custom specifications. The number of deployed nodes is also taken as input for a scalable network evaluation. For air interface mode stochastic process is chosen to randomly distribute sensor nodes on the simulation space of the simulator. Through stochastic process an entirely random distribution is possible. The grid and line distribution

topologies are also included for versatility. EnergySim readily evaluates the residual energies of the nodes and the number of alive and dead nodes after the simulation to estimate network lifetime. The simulator can also calculate the latency by sending data packets from the source to sink node during the rounds simulated. The interoperability and portability gives EnergySim a competitive edge over all prior simulators.

D. Energy Evaluation

After every round, the information pane on the right side of the simulator (shown in the Figs. 2 and 3) indicates the energy state of every node till the final round. The bottom pane shows the spontaneous hand shaking between the simulated nodes showing their immediate states and node ids. These results are then exported to an Excel file and statistical graphs like mean energy, median, standard deviation, latency and contours are generated automatically.

Another unique feature of EnergySim includes customization. We have presented an option to the user to

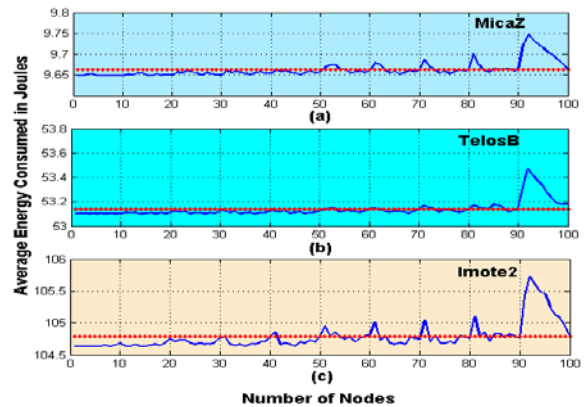

Figure 6: Average energy consumed in seconds for 100 nodes in 50 rounds in Grid topology. Red lines show the mean energy values for 50 rounds. (a) MicaZ (b) TelosB and (c) Imote2.

select the node type and make e.g. imote2, TelosB, MicaZ and

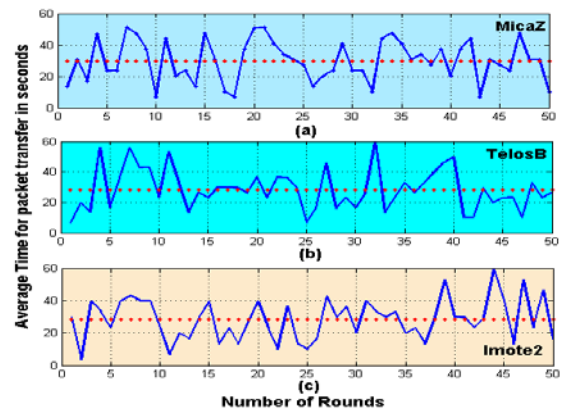

Figure 7: Average time consumed in seconds for packet transfer for 100 nodes in 50 rounds in Grid topology. Red lines show the mean time values for 50 rounds. (a) MicaZ (b) TelosB and (c) Imote2.

Gumstix computers to get away with the hassle of submitting all the parameters related to these motes at the time of

simulation. The node properties specific to energy like Threshold energy ET , Transmission energy ET_x , Receiving energy ER_x and Idle or Sleep state energy $Esleep$ can be completely customized for energy evaluation. These parameters can be input as per the selected MAC protocol in the “Options” dialog box. Some of the properties specific to simulation include number of nodes, initial energy states of the nodes, number of rounds, communication range of the nodes in meters, energies consumed during sending/receiving data, ACK and other control signals. Any other parameter can also be incorporated easily in the simulator. The simulator also shows the intermediate states of the nodes, distance between the nodes in the shortest path and the nodes currently communicating nodes with their range highlighted. This prevents the user from diverting elsewhere and allows the user to focus on the current communication link. Dead nodes are shown in black color (signifying no energy) while alive nodes are shown in white color (signifying maximum energy). The intermediate energy states are shown in a shade of grey.

E. Dynamic Node Layout

Node distribution on simulation screen is an important part of a simulation area optimization to ensure that large number of nodes can occupy the space as well as guarantee the network connectivity. Area based distribution distributes the nodes evenly on the simulation screen, the drawback of this method is that it does not guarantees that a network is maintained and nodes remain connected. Secondly, in case of mobile nodes which is our future extension on this simulator, it may be the case that all nodes moves to the same area of the screen, The node layout is composed of two parts, Normal mode and RFID mode, due to space limitations we will not be discussing the details of their deployment schemes.

III. ENERGYSIM SIMULATION ENGINES

Our simulation architecture can simultaneously support two engines or modes, and depending on the mode chosen at runtime the MAC and other parameters used for the nodes would change. In our initial development we assume that, all the nodes are stationary and may be equipped with one or more sensors and the simulation environment can support more than one type of device for both sensor node and sink. The sink node is considered a more powerful WSN device in comparison to other sensor node in terms of energy and computation power. The communication between the nodes is ideal with no collisions and interference but the path loss model is chosen to determine the communication range. However, these properties will also be incorporated in the simulator in the future for more accurate results. Normal mode engine does not require the nodes to be location aware with no sink node in sight. It also assumes that the nodes in the network are uncomplicated with low power requirements.

A. Normal Mode – Communication Range

Hata [31] is the commonly used path loss model in the industry for planning. Path loss is one of the most important parameters in communication channel prediction model. To calculate the transmission distance path loss equations are taken into consideration. It is a relationship between attenuation, often in decibels (dB), and the distance between transmitter and receiver.

The simplest path loss model occurs when there is no obstacle between transmitter and receiver, equation (a) shows the relationship between the attenuation and the distance between transmitter and receiver in mathematical form, where L is the attenuation in dB , L_0 is path loss at 1 meter, n is the path loss exponent and d is distance in meters.

$$L = L_0 + n.10 \log(d) \tag{a}$$

The path loss equation given in

$$PL(d) = PL(d_0) + 10\gamma \log\left(\frac{d}{d_0}\right) + X_\sigma \tag{b}$$

Where γ is the power-law relationship between the separation distance and the received power, γ is 2 for free space and normally higher for wireless channels [32, 33]. d is the distance between the receiver and the transmitter and d_0 is the received-power reference point. X_σ is the zero-mean Gaussian random variable of standard deviation which reflects the variation, on average, of the received power that naturally occurs.

B. RFID in-pipe channel communication

RFID has become a thriving technology in the supply chain and logistic industries, it was basically developed to help in the identification and management of the goods transported. Mainly the RFID tags are used with air interface with a reading range from few centimeters to few meters. However, some monitoring applications such as oil and gas, water distribution systems and metal piping industries has to deploy these RFID tags within metallic surroundings. The effect of conductive matter is identified as confining factor for RF based WSN applications [34]. RFID generally have difficulties in the conductive environments with like water and metals in

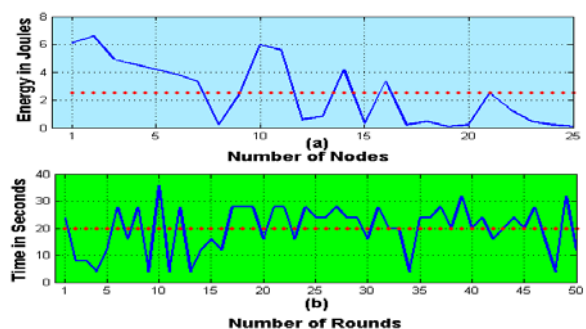

Figure 8: (a) Average Energy Consumed per round for 25 Active RFID motes inside the metal piping structure. (b) Average Time in seconds for packet transfer from the event detection node to the sink node for 50 rounds. Red markers show the mean energy consumed and time taken for the 50 rounds respectively in the current set-up.

their surroundings. Recently, the magnetic induction has been introduced as a new physical layer technique for wireless communication. However it suffers from the high path loss and low bandwidth problems. The well-established wireless signal propagation techniques using electromagnetic (EM)

waves do not work well in underground and metal pipelines environments because of the issues like greater path loss, changing channel conditions and antenna size and optimization. Magnetic Induction communication uses small size loop antennas for transmission and reception. The radiation resistance of such coil antennas is much smaller than electric dipole, hence a very small portion of energy is radiated to the far field by the coil [35]. Therefore there is no issue of the multi-path fading in magnetic induction communications. Some on-going research to enable RFIDs to communicate in such environments can be seen in [1, 36-38]. The difference between our work and Zangl's [36] is that in our work [24] we conducted some experiments using a loop antenna with magnetic field dominant near field low RFID frequencies from 100 – 135 kHz within a copper metal pipe filled with water. The two loop antennas were both inside the same environment at a distance of one and two meters for two experimental setups. We tried to send signals by inducing them on the metal pipe itself and the receiving loop antenna can detect these signals. The results thus obtained were verified using Electromagnetic simulations on Agilent EMPro software [39]. We proposed that by using low RFID frequency range we can communicate within enclosed metallic environment using loop antennas [24].

There were some efforts to characterize the RF propagation for passive RFID in metal pipes are presented in [40-42]. The low frequency RFID signals can be channel modeled using the equation (a) from [36].

$$\vec{U} = 2\pi fN \vec{\phi} \quad (a)$$

Where \vec{U} is the peak induced voltage on the metallic pipe's surface, f is the frequency, N is the number of turns of the loop antenna and $\vec{\phi}$ is the magnetic flux of the coil antenna. We can use this equation to determine the range of the induced voltage on the metallic surface of the pipe in order to determine optimal positioning of the RFID motes within the network.

IV. DISCUSSION AND FUTURE WORK

We have implemented SMAC [19] and TMAC [20] which are the most widely used MAC protocols. We have simulated 50 rounds using 100 nodes in Random and Grid topologies for MicaZ, Imote2 and TelosB [15-18] motes. The radio ranges were selected to be 100 meters for MicaZ and TelosB and 30 meters for Imote2 and SMAC was chosen as the resource sharing mechanism. For MicaZ and TelosB the maximum energy was assigned taking into consideration two alkaline AA sized batteries (18720J[43]) and for Imote2 three alkaline AAA sized batteries (15213J[43]). All the values for the internal mote's energy consumptions like radio, syncing, carrier sensing, sleep, idle etc are assigned according to their datasheets.

The simulations results showing the energy consumptions of the 100 nodes in Random deployment for MicaZ, TeloB and Imote2 are shown in Fig. 4(a-c) respectively. Node '1' is the sink node that explains the higher amount of energy consumed by the sink and its adjacent nodes due to their continuous work

in packet transferring. The simulation results were obtained after the 'Draw Graphs' button was pressed at the end of the simulation. We have obtained an average of 4.53, 17.11 and 35.4 Joules of energy consumed per round for a random event generated for a deployed MicaZ, TelosB and Imote2 based WSNs shown in red lines in fig. 4. That gives an approximate life of 4131, 429 and 1094 rounds of actual event detection for the simulated random topology networks given the full capacity batteries. However, we have to consider the energy consumptions during non detection phases that may make these detection rounds decrease but these figures can give us an approximation which is very near to the actual deployment scenarios. The time the motes spent sending the packets from the event detection node to the sink node for the random topology simulation for these motes is shown in fig. 5(a-c). The time is calculated assuming ideal conditions (no re-transmissions), the average simulated time to complete the transfer per round is found to be approximately 9, 8 and 11 seconds per round for the MicaZ, TelosB and Imote2 respectively. That gives an approximate life span of the simulated networks to be 10, 2.4 and 1.3 hours if events were detected continuously.

Another simulation was performed with Grid topology deploying 100 nodes of MicaZ, TelosB and Imote2 for 50 rounds shown in Fig. 6(a-c). Here node number 93 represents sink node. Hence, sink and its adjacent nodes were consuming more power as expected. We obtained an average of 9.66, 53.1, 104.55 Joules of energy consumed per round for the grid topology. This gives and approximates life in rounds of 1937, 352 and 145 for MicaZ, TelosB and Imote2 respectively. The time the motes spent sending the packets from the event detection node to the sink node for the grid topology simulation is shown in fig. 7(a-c). The time is calculated assuming the same ideal conditions of no re-transmissions, the average simulated time to complete the transfer per round is found to be 30, 28.5 and 28.3 seconds per round shown in fig. 7 with red lines for the MicaZ, TelosB and Imote2 respectively. That gives an approximate life span of the simulated networks to be 16, 2.78 and 1.13 hours if events were detected continuously. Hence, this shows the impact of the topology on the deployed networks' energy consumptions. Similar results can be taken out using TMAC protocol or any other customized protocol to determine network power consumptions and approximating the life time. RFID and other motes can also be used similarly to obtain the results. The simulation results of a RFID deployment inside a piping structure (fig. 3) is shown in fig. 8. The simulation was performed deploying 25 Active RFID nodes including the sink node. Simulation was performed for 50 rounds. Node 1 is the sink node, we obtained an average of 2.5 Joules of energy consumed per round fig. 8(a) and approximated life in number of rounds is 920. The packet delivery time with no re-transmission assumed is shown in fig.8(b). The average simulated time to complete the transfer per round is found to be 20 seconds per round giving an approximate life time of 5.1 hours of continuous events detection. This life span seems to be low as the use of energy consuming sensors for detecting events were also considered.

V. CONCLUSION

The energy efficiency of a system consists of diverse WSN

notes is the new research concern. In this paper we have described a special purpose WSN simulator EnergySim, which is a dynamic, platform independent, rapid prototyping and interoperable multi environment simulation platform for RFID and WSNs. We are extending our work by improving the proposed simulator in terms of both its performance and functionalities.

There are still several features of the simulations that can be further examined. As an example, the inter-node communication currently is understood to occur in an ideal environment; therefore issues like collision, interferences, communication outages, multi-path reflections due to obstacles, have not been fully evaluated. Moreover, there is still more work to be done towards other communication, physical, WSN radio and RFID tag models.

VI. ACKNOWLEDGEMENTS

The first author like to thank NTU for the scholarship during his research work [44]. In addition, the authors would like to acknowledge that part of the research is funded by the Republic of Singapore's National Research Foundation through a grant to the Berkeley Education Alliance for Research in Singapore (BEARS) for the Singapore-Berkeley Building Efficiency and Sustainability in the Tropics (SinBerBEST) Program. BEARS have been established by the University of California, Berkeley as a center for intellectual excellence in research and education in Singapore. This work represents only the views expressed by the respective authors.

REFERENCES

- [1] Adnan Nasir and Boon-Hee Soong, "EnergySim - A Novel, Fast, Extensible Wireless Sensor Network MAC Protocol Simulator for Evaluating Energy Efficiency," in the Proceedings of ICICS, Singapore, December, 2011.
- [2] Bai Yun, Meng Ke-qi-lao, Han Jian-feng, Ren Zhi-gang, and Xin Li, "Mobile network simulation based on NS-2," *Railway Computer Application*, vol. 18, no. 2, p. 22–5, Feb. 2009.
- [3] F. H. Desbrandes, S. Bertolotti, and L. Dunand, "OPNET 2.4: an environment for communication network modeling and simulation," in the Proceedings of Eur Simulation Symposium, p. 609–14, Ghent, Belgium, Oct. 1993.
- [4] G. Pongor, "OMNeT: objective modular network testbed," in International workshop on Modeling, Analysis, and Simulation on Computer and Telecommunication Systems (IEEE Cat. No.93th0514-0), pp. 323–6, San Diego, CA, USA, 1993.
- [5] A. Sobeih, J. C. Hou, K. Lu-Chuan, L. Ning, Z. Honghai, C. Wei-Peng, T. Hung-Ying, and L. Hyuk, "J-Sim: a simulation and emulation environment for wireless sensor networks," in the Proceedings of IEEE Wireless Communications, vol. 13, pp. 104–19, 2006.
- [6] "SNetSim", internet: <http://www.softpedia.com/get/Science-CAD/SNetSim.shtml>, 13 March 2012.
- [7] S. Park, A. Savvides, and M. B. Srivastava, "SensorSim: A simulation framework for sensor networks," in the Proceedings of ACM MSWiM the 3rd ACM International Workshop on Modeling, Analysis and Simulation of Wireless and Mobile Systems, pp. 104–111, Boston, MA, United States, August 2000.
- [8] S. Sundresh, K. Wooyoung, and G. Agha, "SENS: a sensor, environment and network simulator," in proceedings of the 37th annual symposium on simulation: IEEE Computer Society, pp. 221–8, Los Alamitos, CA, USA, 2004.
- [9] P. Levis, N. Lee, M. Welsh, and D. Culler, "TOSSIM: Accurate and scalable simulation of entire TinyOS applications," in Proceedings of the 1st international conference on Embedded networked sensor systems, pp. 126–137, Los Angeles, CA, United States, 2003.
- [10] J. Polley, D. Blazakis, J. McGee, D. Rusk, J. S. Baras, and M. Karir, "ATEMU: A fine-grained sensor network simulator," in the Proceedings of Sensor and Ad Hoc Communications and Networks, 2004. IEEE SECON. First Annual IEEE Communications Society Conference, pp. 145–152, United States, 2004.
- [11] B. L. Titzer, D. K. Lee, and J. Palsberg, "Avrora: scalable sensor network simulation with precise timing," in the Proceedings of Fourth International Symposium on Information Processing in Sensor Networks, IPSN, pp. 477–82, USA, 2005.
- [12] Ma Tao and Shan Hong, "Modeling and simulation of a mobile ad-hoc network based on QualNet," *Electronics Optics & Control*, vol. 16, no. 4, p. 60–4, Apr. 2009.
- [13] S. Sinha, Z. Chaczko, and R. Klempous, R. Moreno-Díaz, F. Pichler, and A. Quesada-Arencibia, Eds. "SNIPER: A Wireless Sensor Network Simulator," in *Computer Aided Systems Theory - EUROCAST 2009*, vol. 5717, pp. 913–920 Berlin, Heidelberg, 2009.
- [14] Y. Sangho, M. Hong, C. Yookun, and H. Jiman, "SensorMaker: A wireless sensor network simulator for scalable and fine-grained instrumentation," in Proceedings of the international conference on Computational Science and its Applications, pp. 800–10, Part I Perugia, Italy: Springer-Verlag Berlin, Germany, 2008.
- [15] L. Nachman, J. Huang, J. Shahabdeen, R. Adler, and R. Kling, "IMOTE2: Serious Computation at the Edge," in the Proceedings of International Wireless Communications and Mobile Computing Conference, IWCMC '08, pp. 1118–1123, Crete, Greece, August 2008.
- [16] A. Prayati, C. Antonopoulos, T. Stoyanova, C. Koulamas, and G. Papadopoulos, "A modeling approach on the TelosB WSN platform power consumption," *Journal of Systems and Software*, vol. 83, no. 8, p. 1355–63, 2010.
- [17] Kramer, M., Gerald, A., "Energy measurements for micaz node," in technical report, Technical University Kaiserslautern, GI/ITG KuVS, 1–7, Rep. 2006.
- [18] K. H. Ko, K. Pochiraju, and S. Manooch, "An embedded system for knowledge-based cost evaluation of molded parts," *Knowledge-Based Systems*, vol. 20, no. 3, pp. 291–299, Apr. 2007.
- [19] John Heidemann and Deborah E. Wei Ye, "Medium Access Control with Coordinated Adaptive Sleeping for Wireless Sensor Networks" in the Proceedings of IEEE Communications Letters, vol. 12 No 3, pp. Pages 493 – 506 J, June 2004.
- [20] Van Dam, Tijs ; Langendoen, Koen, "An Adaptive Energy-Efficient MAC Protocol for Wireless Sensor Networks," in the Proceedings of SenSys'03 the First International Conference on Embedded Networked Sensor Systems, pp. 171–180, Nov. 2003.
- [21] J. Polastre, J. Hill, and D. Culler, "Versatile low power media access for wireless sensor networks," in the Proceedings of the 2nd International Conference on Embedded Networked Sensor Systems, SenSys'04, pp. 95–107, Baltimore, MA, United States, November, 2004.
- [22] C. Floerkemeier and S. Sarma, "RFIDSim—A Physical and Logical Layer Simulation Engine for Passive RFID," in the Proceedings of IEEE Transactions on Automation Science and Engineering, vol. 6, no. 1, pp. 33–43, Jan. 2009.
- [23] M. C. de Azambuja, C. F. Jung, C. S. ten Caten, and F. P. Hessel, "RFID-Env: methods and software simulation for RFID environments," in the Proceedings of Business Process Management Journal, vol. 16, no. 6, pp. 1014–1038, Sep. 2010.
- [24] A. Nasir and B. Soong, "Pipesense: A framework architecture for inpipe water monitoring system," in Communications (MICC), IEEE 9th Malaysia International Conference, pp. 703–708, Kuala Lumpur, 2009.
- [25] Adnan Nasir and Boon-Hee Soong, "WSN-based Human Centric Water Smart Home," in the proceedings of 8th IEEE Asia Pacific Wireless Communication Symposium (IEEE APWCS 2011) Singapore, Aug 2011.
- [26] A. Nasir, B. Soong, and S. Ramachandran, "Framework of wsn based human centric cyber physical in-pipe water monitoring system," in the Proceedings of IEEE 11th International Conference on Control Automation Robotics & Vision (ICARCV), pp. 1257–1261, Singapore 2011.

- [27] E. W. Dijkstra, "A Note on Two Problems in Connection with Graphs," in the Proceedings of Numerische Mathematik, vol. 1, pp. 269-271, 1959.
- [28] Cheng Fu, Hock Beng Lim, Adnan Nasir, Seshan Srirangarajan, Bang Wang, Steven Wong, Boon Hee Soong, "An Integrated Framework for Vehicular and Urban Sensing," in the Proceedings of IEEE Workshop on Networking Intelligent Vehicles and Infrastructures (IEEE NiVi09) Co-located with IEEE GLOBECOM, pp 6, Hawaii, USA, Dec, 2009.
- [29] Adnan Nasir, Hock Beng Lim, Boon Hee Soong, "An Integrated Vehicular and Urban Sensing System: Framework and Modeling" in the conference proceedings of 26th IEEE International Conference on Information Networking (ICOIN), Indonesia, Feb, 2012.
- [30] Adnan Nasir, Boon-Hee Soong, "EnvironSense: An Integrated system for Urban Sensing using RFID based WSN's," in proceedings of the IEEE TENCON 2009 IEEE Region 10 Conference, pp 5, November 2009.
- [31] M. Hata., "Empirical formula for propagation loss in land mobile radio service," in the Proceedings of IEEE Transactions on Vehicular Technology, Vol. VT-29, pp.317-325, Sep 1981.
- [32] V. Erceg, L. J. Greenstein, et al., "An empirically based path loss model for wireless channels in suburban environments," in the Proceedings of IEEE Journal on Selected Areas of Communications, Vol. 17, pp. 1205-1211, July 1999.
- [33] J. Kunthong and C. F. Bunting, "A novel hybrid propagation model," in the Proceedings of IEEE Antennas and Propagation Society International Symposium, AP-S, pp. 1-4, 2008.
- [34] T. Jariyanorawiss and N. Homsup, "Power Comparison between a Mobile Phone Operated at 1.8 GHz and 900 MHz near a Metal Wall," in the Proceedings of International Symposium on Communications and Information Technologies, ISCIT '06, pp. 336-339, 2006.
- [35] Zhi Sun and I. F. Akyildiz, "Magnetic Induction Communications for Wireless Underground Sensor Networks," in the Proceedings of IEEE Transactions on Antennas and Propagation, vol. 58, no. 7, pp. 2426-2435, Jul. 2010.
- [36] H. Zangl, A. Fuchs, T. Bretterkieber, M. J. Moser, and G. Holler, "Wireless Communication and Power Supply Strategy for Sensor Applications Within Closed Metal Walls," in the Proceedings of IEEE Transactions on Instrumentation and Measurement, vol. 59, no. 6, pp. 1686-1692, Jun. 2010.
- [37] A. Fuchs, H. Zangl, and G. Brasseur, "Mass Flowmeter for Screw Conveyors Based on Capacitive Sensing," in the Proceedings of IEEE Instrumentation and Measurement Technology Conference, IMTC, pp. 1-5, 2007.
- [38] H. Zangl, A. Fuchs, T. Bretterkieber, M. Moser, and G. Holler, "An Investigation on Wireless Communication and Power Supply Through Metal Tank Walls," in the Proceedings of IEEE Instrumentation and Measurement Technology Conference Proceedings, IMTC, pp. 1452-1457, 2008.
- [39] F. Demuyneck, "Innovation in computational electromagnetics at Agilent technologies," in Proceedings of the 5th European Conference on Antennas and Propagation (EUCAP), pp. 3020-3021, 2011.
- [40] D. D. Arumugam and D. W. Engels, "Characterization of passive UHF RFID tags in toroidal metal pipes," in the Proceedings of IEEE Antennas and Propagation Society International Symposium, APSURSI '09, pp. 1-4, 2009.
- [41] D. D. Arumugam and D. W. Engels, "Characterization of RF Propagation in Helical and Toroidal Metal Pipes for Passive RFID Systems," in the Proceedings of IEEE International Conference on RFID, pp. 269-276, 2008.
- [42] D. D. Arumugam and D. W. Engels, "Characterisation of RF propagation in metal pipes for passive RFID systems," in the Proceedings of International Journal of Radio Frequency Identification Technology and Applications, vol. 1, no. 3, pp. 303 - 343, 2007.
- [43] "All about batteries." Available at internet: <http://www.allaboutbatteries.com/Energy-tables.html>, 06 March 2012.
- [44] A. Nasir, Investigatio into Energy Efficient Wireless Sensor Networks for Smart Monitoring and Sensing Applications, PhD Thesis, NTU 2013.



Adnan Nasir received his B.Eng. degree in Electronics Engineering from NED University of Engineering and Technology Karachi, Pakistan in 2003. He is currently pursuing his Ph.D. degree from Nanyang Technological University of Singapore. He is also working as a Research Assistant in Texas A&M University at Qatar since 2012. His research interests include

wireless sensor networks, RFIDs, Cognitive and Cooperative Networks, Visible Light Communications and resource management of wireless networks. He is also a Member of IEEE.



Boon-Hee Soong (M'90, SM'04) received his B.Eng. (Hons I) degree in Electrical and Electronic Engineering from University of Auckland, New Zealand and a Ph.D. degree from the University of Newcastle, Australia, in 1984 and 1990 respectively. He is currently an Associate Professor with the School of Electrical and Electronic Engineering, Nanyang

Technological University. His research interests include wireless sensor networks, MANET, mobility issues, and resource management of wireless networks; He has over 100 publications in leading international journals and conferences papers. He is a Senior Member of IEEE and a member of ACM.