

Induced Disturbance in Power Network by Lightning

Senaa Kaouche, Bachir Nekhoul, Kamel Kerroum and Khalil El Khamlichi Drissi

Abstract: In this work the transient analysis of a power network excited by indirect lightning is performed directly in time domain. Using the FDTD, we calculate induced currents and voltages in each node for a three-phase power network. The topological analysis of the network where each element (power line and lumped charge) is considered, allows deducing the matrix equation. In this electrical network matrix, power lines are represented by line equations, junctions and extremities nodes by Kirchhoff laws. The electromagnetic field emitted by lightning is represented in the second member of this matrix equation. The frequency dependence of the line parameters is taken in account while using time domain convolution.

Index terms: lightning strock, disturbance, power network, coupling.

I. INTRODUCTION

Lightning protection of power network has always been a problem receiving much attention, particularly after high-voltage lines came into use. Also naturally occurring, lightning pose a severe threat to modern electronic equipment. The overvoltages induced on power network by indirect lightning strokes represent one of the most cause of disturbance and disruption of the distribution systems.

Actually many methods have been developed for studying the coupling between electromagnetic field generated by lightning and power or transmission line. Among the papers most recent of time domain or frequency domain analysis realised only for a line or cable, we mention E. Petrache and all [1].

In this paper, a new formalism is introduced and allows considering a complex network with interconnection nodes and terminated surges. This approach is developed while using the Taylor MTL equations and the expression representing the localized networks (based on the Kirchhoff laws) proposed by C.R. Paul [2].

For this objective, after FDTD discretization of the lines equations excited by lightning and application of Kirchhoff laws in the interconnection and extremities nodes, we deduce the matrix equation ($[A][X]=[B]$). In this equation the electrical topology of the network is taken into account in matrix $[A]$, the excitation field in vector $[B]$ and the vector $[X]$ contain the unknown induced currents and voltages.

The lightning stroke is modelled by a vertical antenna above the ground. The produced electromagnetic field is evaluated using dipole method for either a perfect ground or a soil of finite conductivity.

Manuscript received February 5, 2007 and revised March 7, 2007.

Senaa Kaouche and Bachir Nekhoul are both with the LAMEL Laboratory, University of Jijel, Algeria

Kamel Kerroum and Khalil El Khamlichi Drissi are both with the LASMEA laboratory, Blaise Pascal University, France

II. COUPLING OF AN EXTERNAL ELECTROMAGNETIC FIELD TO OVERHEAD LINE

Voltages and currents along the overhead line induced by a lightning can be calculated using the field-to-transmission line equations expressed in the frequency domain [2]:

$$\frac{d}{dz} \begin{bmatrix} \vec{V}(z) \\ \vec{I}(z) \end{bmatrix} + \begin{bmatrix} \vec{Z} \\ \vec{Y} \end{bmatrix} \begin{bmatrix} \vec{V}(z) \\ \vec{I}(z) \end{bmatrix} = \begin{bmatrix} \vec{V}_F(z) \\ \vec{I}_F(z) \end{bmatrix} \quad (1)$$

$$\frac{d}{dz} \begin{bmatrix} \vec{I}(z) \\ \vec{V}(z) \end{bmatrix} + \begin{bmatrix} \vec{Y} \\ \vec{Z} \end{bmatrix} \begin{bmatrix} \vec{I}(z) \\ \vec{V}(z) \end{bmatrix} = \begin{bmatrix} \vec{I}_F(z) \\ \vec{V}_F(z) \end{bmatrix} \quad (2)$$

the longitudinal impedance matrix is:

$$\vec{Z} = j\omega \begin{bmatrix} \vec{L} \\ \vec{Z}_w \end{bmatrix} + \begin{bmatrix} \vec{Z}_g \end{bmatrix} \quad (3)$$

and the transversal admittance is :

$$\vec{Y} = j\omega \begin{bmatrix} \vec{C} \end{bmatrix} + \begin{bmatrix} \vec{G} \end{bmatrix} \quad (4)$$

$[\vec{L}]$: the per-unit length longitudinal inductance matrix for a perfect soil; $[\vec{C}]$ and $[\vec{G}]$ are respectively the per-unit length transverse capacitance and conductance matrixes of the multiconductor line;

\vec{Z}_w : the per-unit length internal impedance matrix of the conductors (generally neglected for aerial line);

\vec{Z}_g : the per-unit length ground impedance matrix.

$\vec{V}_F(z)$ and $\vec{I}_F(z)$: sources vectors expressed respectively in terms of the incident magnetic field, incident electric field [2].

The field-to-transmission line coupling equations (1) and (2) can be converted into the time domain to obtain the following expressions:

$$\frac{\partial}{\partial z} \begin{bmatrix} \vec{V}(z, t) \\ \vec{I}(z, t) \end{bmatrix} + \begin{bmatrix} \vec{L} \\ \vec{Y} \end{bmatrix} \frac{\partial}{\partial t} \begin{bmatrix} \vec{I}(z, t) \\ \vec{V}(z, t) \end{bmatrix} + \begin{bmatrix} \vec{Z}'(t) \\ \vec{C} \end{bmatrix} * \begin{bmatrix} \vec{I}(z, t) \\ \vec{V}(z, t) \end{bmatrix} = \begin{bmatrix} \vec{V}_F(z, t) \\ \vec{I}_F(z, t) \end{bmatrix} \quad (5)$$

$$\frac{\partial}{\partial z} \begin{bmatrix} \vec{I}(z, t) \\ \vec{V}(z, t) \end{bmatrix} + \begin{bmatrix} \vec{G} \\ \vec{Z} \end{bmatrix} \begin{bmatrix} \vec{V}(z, t) \\ \vec{I}(z, t) \end{bmatrix} + \begin{bmatrix} \vec{C} \\ \vec{L} \end{bmatrix} \frac{\partial}{\partial t} \begin{bmatrix} \vec{V}(z, t) \\ \vec{I}(z, t) \end{bmatrix} = \begin{bmatrix} \vec{I}_F(z, t) \\ \vec{V}_F(z, t) \end{bmatrix} \quad (6)$$

* : convolution product ;

$\vec{z}'(t)$: inverse Fourier transform of $\begin{bmatrix} \vec{Z}_g \end{bmatrix}$;

$[V_F(z, t)]$ and $[I_F(z, t)]$: respectively, inverse Fourier transform of $[\hat{V}_F(z)]$ and $[\hat{I}_F(z)]$ [2]; which can be expressed as follows [3]:

$$[V_F(z, t)] = -\frac{\partial}{\partial z} [E_T(z, t)] + [E_L(z, t)] \quad (7)$$

$$[I_F(z, t)] = -[G][E_T(z, t)] - [C] \frac{\partial}{\partial t} [E_T(z, t)] \quad (8)$$

$[E_T(z, t)]$: the transverse incident field sources;

$[E_L(z, t)]$: the longitudinal field sources.

A. Transient Ground Resistance in Time Domain

For an overhead line the ground admittance is generally neglected. However, it is important to take in consideration the frequency variation of the ground impedance. In the time domain, F. Rachidi and al [4] propose an analytical inverse Fourier transform for $([\hat{Z}_g/j\omega])([\zeta_g] = F^{-1}([\hat{Z}_g/j\omega])$: transient ground resistance matrix), of which the elements are given by

$$\zeta_{gij}(t) = \min \left\{ \frac{1}{2\pi h} \sqrt{\frac{\mu_0}{\varepsilon_0 \varepsilon_{rg}}}, \frac{\mu_0}{\pi T_{ij}} \left[\frac{1}{2\sqrt{\pi}} \sqrt{\frac{T_{ij}}{t}} \times \right. \right. \\ \left. \left. \cos(\theta_{ij}/2) + \frac{1}{4} e^{(T_{ij} \cos(\theta_{ij})/t)} \cdot \cos\left(\frac{T_{ij}}{t} \sin(\theta_{ij}) - \theta_{ij}\right) \right. \right. \\ \left. \left. - \frac{1}{2\sqrt{\pi}} \sum_{n=0}^{\infty} a_n \left(\frac{T_{ij}}{t}\right)^{\frac{2n+1}{2}} \cos\left(\frac{2n-1}{2} \theta_{ij}\right) - \frac{\cos(\theta_{ij})}{4} \right] \right\} \quad (9)$$

Then the equation (5) becomes:

$$\frac{\partial}{\partial z} [V(z, t)] + [L] \frac{\partial}{\partial t} [I(z, t)] + \int_0^t [\zeta_g(t-\tau)] \frac{\partial}{\partial \tau} [I(z, \tau)] d\tau \\ = -\frac{\partial}{\partial z} [E_T(z, t)] + [E_L(z, t)] \quad (10)$$

If Δt is enough small, after some mathematical manipulations of the integral that appears in (10), E. F. Vance rewrites the equation (10) as follow [5]:

$$\frac{\partial}{\partial z} [V(z, t)] + [L] \frac{\partial}{\partial t} [I(z, t)] + [u_1(z, t)] + [u_2(z, t)] \\ = -\frac{\partial}{\partial z} [E_T(z, t)] + [E_L(z, t)] \quad (11)$$

$$[u_2(z, t)] \approx 2 \cdot [[I(z, t)] - [I(z, t - \Delta t)]] [\zeta_g(\Delta t)] \quad (12)$$

$$[u_1(z, t)] = \int_0^{t-\Delta t} [\zeta_g(t-\tau)] \frac{\partial}{\partial \tau} [I(z, \tau)] d\tau \quad (13)$$

B. Coupling Equations Expressed in Time Domain by Finite Differences

The coupling MTL equations (6) and (11) in the time domain, taking into account the transient ground resistance, are written using FDTD. The derivatives in the MTL equations are discretized and approximated with second-order central finite differences [3] and we denote:

$$[V_k^n] \equiv [V[(k-1)\Delta z, n\Delta t]] \quad (14)$$

$$[I_k^n] \equiv \left[I \left[\left(k - \frac{1}{2} \right) \Delta z, n\Delta t \right] \right] \quad (15)$$

knowing that [5]:

$$[u_{1,k}^n] = \sum_{j=0}^{n-1} [\zeta_g((n-j)\Delta t)] \frac{[I_k^{j+1}] - [I_k^j]}{\Delta t} \Delta t \quad (16)$$

$$[u_{2,k}^n] = 2 \cdot ([I_k^n] - [I_k^{n-1}]) [\zeta_g(\Delta t)] \quad (17)$$

$$\frac{[u_{1,k}^{n+1}] + [u_{1,k}^n]}{2} = \frac{1}{2} [\zeta_g(\Delta t)] ([I_k^{n+1}] - [I_k^n]) + \\ \frac{1}{2} \cdot \sum_{j=0}^{n-1} \{ [\zeta_g((n-j)\Delta t)] + [\zeta_g((n+1-j)\Delta t)] \} \\ \cdot ([I_k^{j+1}] - [I_k^j]) \quad (18)$$

$$\frac{[u_{2,k}^{n+1}] + [u_{2,k}^n]}{2} = ([I_k^{n+1}] - [I_k^{n-1}]) [\zeta_g(\Delta t)] \quad (19)$$

We deduce:

$$\left(\frac{[L]}{\Delta t} + \frac{3}{2} [\zeta_g(\Delta t)] \right) [I_k^{n+1}] = \left(\frac{[L]}{\Delta t} + \frac{1}{2} [\zeta_g(\Delta t)] \right) [I_k^n] + \\ [\zeta_g(\Delta t)] [I_k^{n-1}] - \frac{[V_{k+1}^{n+1}] - [V_k^{n+1}]}{\Delta z} \\ - \frac{1}{2} \cdot \sum_{j=0}^{n-1} \{ [\zeta_g((n-j)\Delta t)] + [\zeta_g((n+1-j)\Delta t)] \} ([I_k^{j+1}] - [I_k^j]) \\ - \frac{[E_{T,k+1}^{n+1}] - [E_{T,k}^{n+1}]}{\Delta z} + \frac{[E_{L,k}^{n+1}] + [E_{L,k}^n]}{2} \\ k = 1, 2, \dots, ndz \quad (20)$$

$$\begin{aligned} & \left(\frac{[C]}{\Delta t} + \frac{[G]}{2} \right) \cdot [V_k^{n+1}] - \left(\frac{[C]}{\Delta t} - \frac{[G]}{2} \right) [V_k^n] - \frac{[I_k^n] - [I_{k-1}^n]}{\Delta z} \\ & - [G] \frac{[E_{T,k}^{n+1}] + [E_{T,k}^n]}{2} - [C] \frac{[E_{T,k}^{n+1}] - [E_{T,k}^n]}{\Delta t} \end{aligned} \quad (21)$$

$k = 2, 3, \dots, ndz$

C. Terminal Conditions

Next, consider the incorporation of the terminal conditions. The essential problem here is that the FDTD voltages and currents at each end of the line are not collocated in space or time, whereas the terminal conditions relate the voltage and current at the same position and at the same time. Then, remains the determination of terminal currents and voltages, i.e. at $z = 0$ and $z = L$ and at the same time $(n+1)\Delta t$. These unknowns are designed by $I^{n+1}(0)$, $I^{n+1}(L)$, $V^{n+1}(0)$ and $V^{n+1}(L)$. They are obtained by substituting Δz with $\Delta z/2$ in (21) for $k=1$ and $k = ndz + 1$ and by introducing the finite difference approximation of currents at $(n+1)\Delta t$. We obtain:

- for $k = 1$

$$\begin{aligned} & \left(\frac{[C]}{\Delta t} + \frac{[G]}{2} \right) \cdot [V^{n+1}(0)] - \frac{[I^{n+1}(0)]}{\Delta z} = \\ & \left(\frac{[C]}{\Delta t} - \frac{[G]}{2} \right) \cdot [V^n(0)] - \frac{[I_1^n]}{(\Delta z/2)} + \frac{[I^n(0)]}{\Delta z} \\ & - [G] \frac{[E_{T,1}^{n+1}] + [E_{T,1}^n]}{2} - [C] \frac{[E_{T,1}^{n+1}] - [E_{T,1}^n]}{\Delta t} \end{aligned} \quad (22.a)$$

- for $k = ndz + 1$

$$\begin{aligned} & \left(\frac{[C]}{\Delta t} + \frac{[G]}{2} \right) \cdot [V^{n+1}(L)] + \frac{[I^{n+1}(L)]}{\Delta z} = \\ & \left(\frac{[C]}{\Delta t} - \frac{[G]}{2} \right) \cdot [V^n(L)] + \frac{[I_{ndz}^n]}{(\Delta z/2)} - \frac{[I^n(L)]}{\Delta z} \\ & - [G] \frac{[E_{T,ndz+1}^{n+1}] + [E_{T,ndz+1}^n]}{2} - [C] \frac{[E_{T,ndz+1}^{n+1}] - [E_{T,ndz+1}^n]}{\Delta t} \end{aligned} \quad (22.b)$$

The difference between our method and other methods based on the same technique is that terminal currents are not obtained by extrapolating the currents at the closest two current nodes. These terminal currents are considered as unknowns in the problem. The MTL system (22) of $(2Ni)$ equations with $(4Ni)$ unknowns must be completed by a second system which corresponds to the boundary conditions at interconnection networks (Ni : number of i^{th} line

conductors). This second system will be described in the following section.

III. ELECTRICAL MATRIX SYSTEM FOR A NETWORK

Consider a power network which contains NL uniform MTL's interconnected by M localized networks (nodes). Each MTL contains Ni ($i=1\dots NL$) conductors. The network can be illuminated by an incident electromagnetic field and/or can be excited by a transient pulse generator which is located at any circuit (localized network).

The first step allows defining a matrix $[A]$ composed of two submatrixes:

$$[A] = \begin{bmatrix} [A_1] \\ [A_2] \end{bmatrix} \quad (23)$$

$[A_1]$ is the submatrix deduced from system (22) for all tubes (lines) and $[A_2]$ is the submatrix deduced from Kirchhoff's laws (KCL and KVL) for junctions (terminations' and interconnections' networks) [2].

Once matrix $[A]$ constructed, the resolution of the equation (24) allows obtaining unknown electrical variables.

$$[A] \times [X] = [B] \quad (24)$$

$[X]$: Unknown vector (current and voltage nodes);

$[B]$: Source vector.

A. Submatrix of Tubes $[A_1]$

The submatrix $[A_1]$ is obtained while writing for each line the system (22).

For the i^{th} tube of Ni conductors, the submatrix $[A_1]$ is as follows :

$$[A_1] = \begin{bmatrix} \left(\frac{[C]}{\Delta t} + \frac{[G]}{2} \right) - \frac{1}{\Delta z} [I_{Ni}] & [0] \\ [0] & [0] & \left(\frac{[C]}{\Delta t} + \frac{[G]}{2} \right) \\ \vdots & \vdots & \vdots \\ [0] & [0] & [0] \\ \\ [0] & [0] & \dots & [0] \\ + \frac{1}{\Delta z} [I_{Ni}] & [0] & \dots & [0] \\ \vdots & \dots & & \\ [0] & \dots & & \end{bmatrix} \quad (25)$$

$[I_{Ni}]$: identity matrix of Ni order ;

B. Submatrix of Junctions [A₂]

In this section we propose the construction of submatrix [A₂] representing all nodes of the transmission network. Let's suppose that we want to characterize the m-th interconnection network shown in Fig. 1., which interconnects n tubes. Voltages and currents of these tubes, in this m-th network, can be linked by the following relation (combination of Thévenin and Norton theorems) [2]:

$$\sum_{i=1}^n \left([Y_i^m] \cdot [V_i^m] + [Z_i^m] \cdot [I_i^m] \right) = [P^m] \quad (26)$$

[Y₁^m]: Resultant matrixes from the application of Kirchhoff's laws (KVL and KCL) in the m-th network, which can contain the numerical values 0, 1, -1 and admittances values according to the network topology,

[Z₁^m]: Resultant matrixes from the application of Kirchhoff's laws (KVL and KCL) in the m-th network, which can contain the numerical values 0, 1, -1 and impedances values according to the topology of the network,

[P^m]: Vector containing equivalent Thévenin or Norton sources.

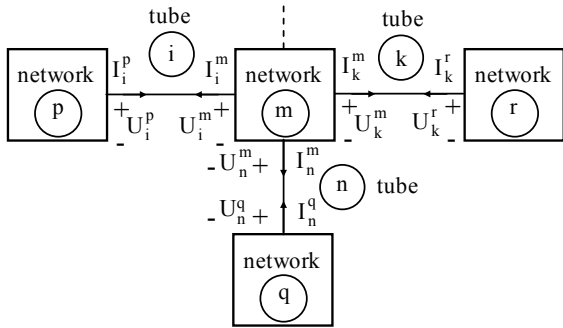

Fig. 1. Definition of voltages and currents in a transmission network.

It must be noted, that the total number of equations in expression (26) equals to the number of incident conductors at the network (node).

The submatrix [A₂] can be constructed by application of Thévenin and Norton's theorems in each localized network.

C. Unknown Vector [X]

The unknown vector includes the current and voltage nodes. For the ith line at the time n.Δt, we have:

$$[X] = \left[\dots \begin{bmatrix} V_i^n(0) \\ I_i^n(0) \end{bmatrix} \begin{bmatrix} V_i^n(L) \\ I_i^n(L) \end{bmatrix} \dots \right]^t \quad (27)$$

D. Source Vector [B]

This vector is composed of two subvectors [B₁] and [B₂], as:

$$[B] = \begin{bmatrix} [B_1] \\ [B_2] \end{bmatrix} \quad (28)$$

The subvector [B₁] is deduced while writing the system (22) for every tube (line), it includes the second member of this system. The subvector [B₂], contains the equivalent Thévenin and/or Norton sources (equation (26)) for each node (localized network).

IV. APPLICATIONS

A. Case of a Power Line

At first we consider a simple example consisting on the calculation of currents and voltages of a triphase line (height of conductors is 10m and horizontal distances is 3.7m) illuminated by a lightning wave as illustrated in Fig. 2. This considered example has already been studied by A. Andreotti and all [6].

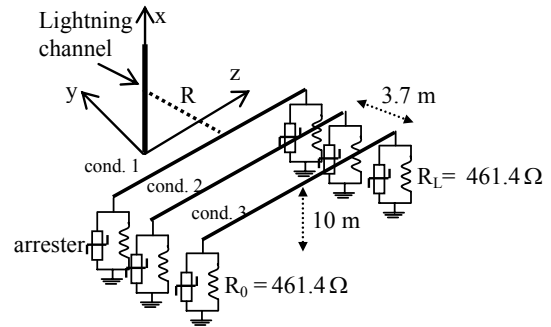

Fig. 2. Geometry considered.

Two cases are treated, a perfect conducting ground and a finite conductivity ground. We compute electromagnetic field emitted by the lightning by use of dipoles formalism [7]. In case of a perfect conducting ground, we consider directly the image and we apply the superposition principle. For a finite conducting soil, longitudinal component of electric field is corrected by use of M. Rubeinstien approximation [8]; in this case the IFFT is used. Datas lightning channel are given in [6]. For the calculation of the current distribution along the channel lightning, we use F. Heidler [8] expression for the channel base current, and the MTL model [8] for the return stroke.

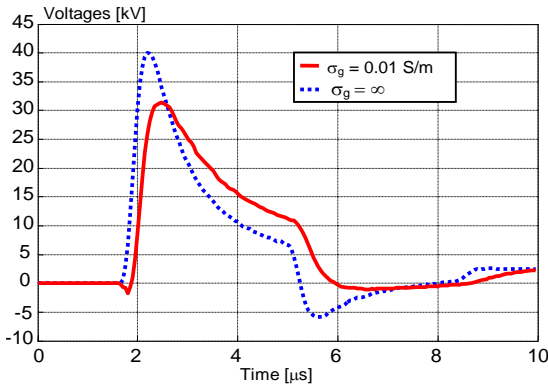

Fig. 3. Voltages induced on the central conductor.

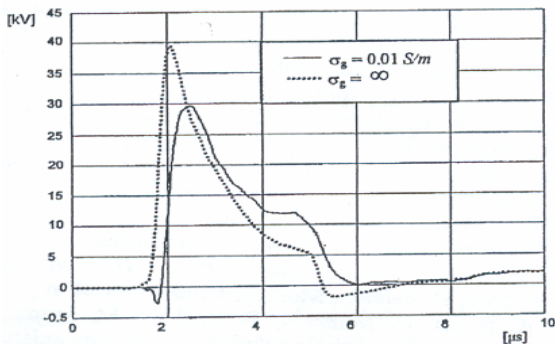

Fig. 4. Voltages induced on the central conductor [6].

In this application, we can affirm that our formalism (Fig. 3.) give similar results to those published (Fig. 4.) by A. Andreotti [6] in which he represents the lightning wave along the line by generators at its' extremities.

The formalism proposed by A. Andreotti is certainly interesting, however the author affirms it self that it's unable to treat a network with a complex topology.

For this same example we consider the case when the line conductors are terminated at both ends with the characteristic impedance and the static surge-arrester (See Fig.2.) governed by the following nonlinear equation (*static characteristic*):

$$i = k \cdot (v/v_{ref})^n, \text{ with } k = 2.5 \text{ kA}, n = 24 \text{ and } v_{ref} = 40 \text{ kV}.$$

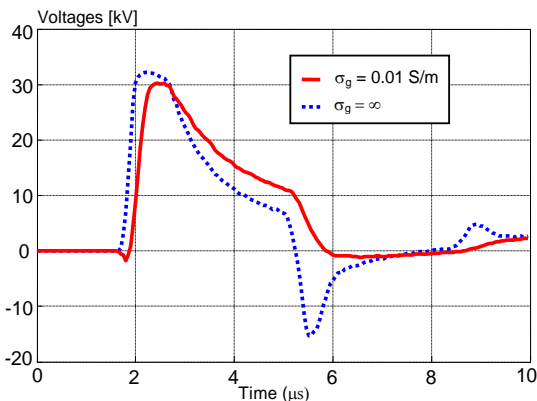

Fig. 5. Voltages induced on the central conductor in presence of static surge arresters.

Fig. 5 shows the induced voltages at the line ends in presence of surge arresters. We will notice the role of the arrester that is the chopping of voltage. It is clear that in this case the $[X]=[B]$ system becomes nonlinear.

B. Case of a network with complexe topology

In our second application we consider three triphase lines connected in Y, as shown Fig. 6. Knowing that the lines lengths are $L_1 = 5 \text{ km}$, $L_2 = 3 \text{ km}$, $L_3 = 6 \text{ km}$.

In order to verify the conformity of induced voltages or currents with used Y geometry, we opt for a particular choice of surges (R_0 and R_L).

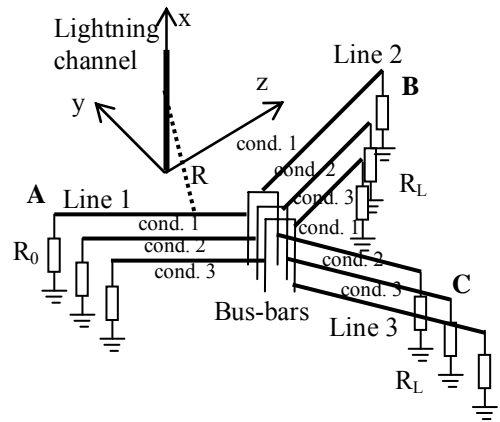

Fig. 6. Geometry considered.

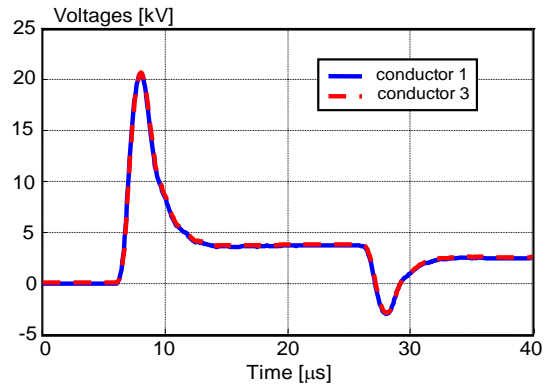

Fig. 7. Induced voltages at A extremity.

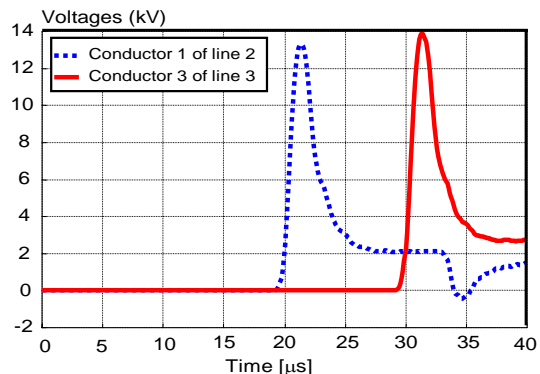

Fig. 8. Induced voltages at B and C extremities.

In Fig. 7 it appears clearly that induced voltages at extremity **A** of conductors 1 and 3 are superimposables. In Fig. 8 we see also that induced voltages at **B** extremity of conductor 1 and at **C** extremity of conductor 3 have practically the same magnitudes. Induced voltage at **B** extremity and the only difference is the time delay. All these remarks reinforce well our modelling.

C. Case of a radial network of multicore cables

In this example we have a network of nine shielded multicore cables with a radial geometry (Fig. 9.). Our calculation results will be compared with those measured by France-Telecom [9]. All data of the lightning channel are given in [9].

The multicore shielded cable (3 cores) is 2588m long and 4m above the lossy ground. The conductivity and relative permittivity of the ground are assumed to be equal to 0.001S/m and 10, respectively. The electrical resistance of the shield is 2.9 Ω /km. The shield of the cable is ended at the extremities by two resistances of 40 Ω and 228 Ω respectively and grounded at the first extremity of the segment 4.

We notice that the approximation proposed by E. F. Vance for transient resistance is not used in this application; indeed, this approximation applies only for overhead lines. In order to treat this example, the per unit line parameters are calculated for a fixed frequency of 800 Hz. The choice of this frequency is in conformity with the study published by the group N° 5 of CIGRE [10], where it's indicated that the magnitude error doesn't exceed 5%, with a small modification of the general shape of electric quantities at transient analysis in a lines or cables network.

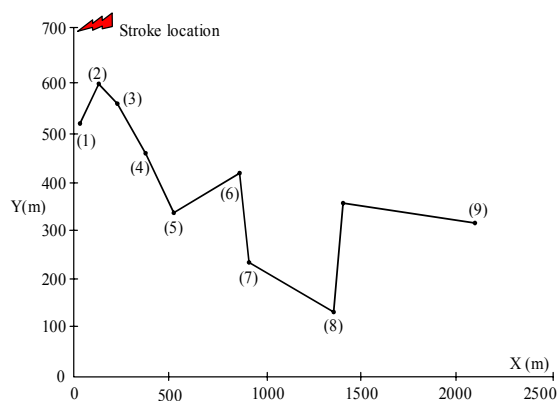

Fig. 9. Multicore cable route used in measurement.

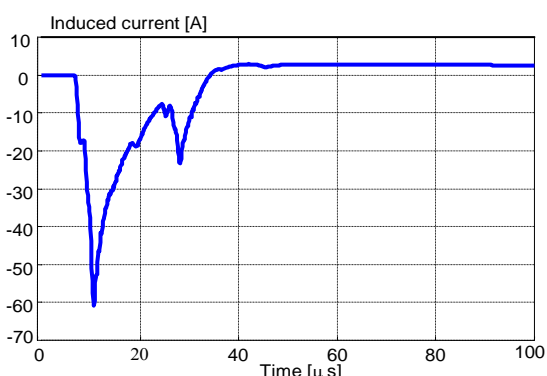

Fig. 10. Computed current at the second extremity of the 9th cable shield by proposed formalism.

Comparison of computed result with France-Telecom measure [9] (Fig. 10. and .11.), shows that both of magnitude and general shape are conserved. We respect also the remarks given by the group N° 5 of CIGRE [10]. Normally, this result will be substantially ameliorated if we treat the term of the correction impedance for an overhead cable similarly to the manner proposed by E. F. Vance [5].

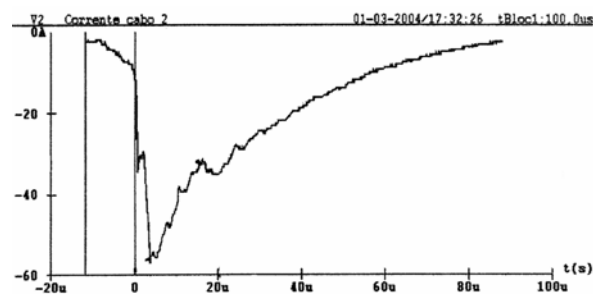

Fig. 11. Measured current at the second extremity of the 9th cable shield [9].

V. CONCLUSION

This new approach proposed for the analysis of the coupling lightning stroke with complex power network conduct to very satisfactory results. The proposed formalism provides not only the analysis of a power network with complex topology, but also allows the treatment directly in time domain. This last advantage allows us to avoid numerical disturbances which appear in frequency analysis by use of many Fourier transforms.

Our new approach appears preferable because it allows taking in account nonlinear phenomena such as the presence of nonlinear protective devices at the line terminals. The extension of this approach for a cables network (while taking in account the transient impedance) is actually in progress.

REFERENCES

- [1] E. Petrache, F. Rachidi, M. Paolone, C. A. Nucci, V. A. Rakov, and M. A. Uman, *Lightning Induced Disturbances in Buried Cables-Part I: Theory*, IEEE Transactions on Electromagnetic Compatibility, Volume 47, N° 3, Aug. 2005, pp.498 – 508.
- [2] C. R. Paul, *Analysis of Multiconductor Transmission Lines*, John Wiley & Sons, Inc., New York, 1994.
- [3] Antonio Orlandi, C. R. Paul, *FDTD Analysis of Lossy, Multiconductor Transmission Lines Terminated in Arbitrary Loads*, IEEE Transactions on Electromagnetic Compatibility, Volume 38, N° 3, Aug. 1996, pp.388 – 399.
- [4] F. Rachidi, S. L. Loyka, C. A. Nucci, M. Ianoz, A new expression for the ground transient resistance matrix elements of multiconductor overhead transmission lines, *Electric Power Systems Research* 65 (2003) 41-46.
- [5] E. F. Vance, *Coupling to Shielded Cables*, Wiley Interscience, New York, 1979.
- [6] A. Andreotti, U. De Martinis, A. Maffucci, G. Miano, L. Verolino, *Non-Linear Behaviour of LEMP Excited Power Lines Terminated on Surge-Arresters*, in Proc. IEEE 1999 Int. Symp. EMC, Vol. 2, pp. 648 – 653, Aug. 1999.

- [7] M. A. Uman, D. Kenneth Mc Lain and E. Philip Krider, The Electromagnetic radiation from finite antenna, American Journal Physics, Vol. 43/33, pp.33-38, January 1975.
- [8] C.A. Nucci "Lightning-Induced Over Voltages on Overhead Power Lines. Part 1: Return-Stroke Current Models with Specified Channel-Base Current for the Evaluation of Return-Stroke Electromagnetic Field", Cigré paper prepared within the framework of task Force 33.01.01 of the CIGRE working Group 33.01,1994.Electra N°161, August 1995.
- [9] Gastaldi E F., José Pissolato F., Rossi J A., Computer Simulation of some Lightning Effects on a Telecommunication Network, in Proc, International Symposium on Electromagnetic Compatibility, EMC 2004, Vol. 2, pp. 452-457, Aug. 2004.
- [10] Working Group 05 CIGRE, Calculation of Switching Surges, Electra N° 62. 1973.



Senaa Kaouche was born in Jijel, Algeria in 1979. She received a state Engineer degree and an MSc degree in Electrical Engineering from the University of Jijel in 2001 and 2003. Actually she is lecturer at the University of Jijel where she will present her PHD in June 2007. Her main research areas are Electromagnetic compatibility.



has several published papers in IEEE and others international reviews.

Bachir Nekhoul was born in Jijel, Algeria in 1957. He received a state Engineer degree in Electrical Engineering from Polytechnic School of Algiers and a PhD degree in Electrical Engineering from the National Polytechnic institute of Grenoble, France. Actually he is a professor at the University of Jijel.

His main research area is Electromagnetic Compatibility in Electrical Engineering where he



Compatibility, antennas and propagation.

Kamel Kerroum was born in Jijel, Algeria in 1954. He received a state Engineer degree in Electrical Engineering from Polytechnic School of Algiers and a PhD degree in Electrical Engineering from Blaise Pascal University of Clermont Ferrand, France. Actually he is a Lecturer at Blaise Pascal University.

His main research areas are Electromagnetic



Khalil El Khamlichi Drissi was born in Fez, Morocco in 1965. He received MS (1987) and PhD (1990) degrees in Electronics from the University of Lille, FRANCE.

He is actually Professor at the CUST in Electrical Engineering department. His main research is about EMC in Power Electronics, especially Numerical Modelling, EMI reduction and Power Converter Control.